

## Sensor Activated Clean Dry™ High Speed Concealed Hand Dryer

### FEATURES

---

- AC powered hand dryer, equipped with very fast and quiet motor providing 224 mph air speed with only 62 dB noise rating
- Takes only 12 seconds to dry hands
- Touch free infra red sensor activation with power saving function which turns the motor off automatically when hands are removed or after 60 seconds of use
- Drip tray to prevent water from trickling to the floor
- Hard wired
- Mounts flush with the wall for clean design
- Flush mounting deters vandalism
- Quality, attractive construction with stainless steel body

### COLORS/FINISHES

---

- #SS Stainless Steel

### CODES/STANDARDS

---

- Meets or exceeds UL507, CSA C22.2 #113-M1984
- Certifications: Intertek/ETL
- Code Compliance: NEC, CEC
- ADA compliant



### PRODUCT SPECIFICATION

---

TOTO® Model No. \_\_\_\_\_  
Automatic infrared sensor activated, high speed hand dryer. 120 V AC power hardwiring required. Decibel rating of 58dB for low noise level while providing 224 mph air speed for fast drying. Low power consumption of 510 Watts. Drain Tray to collect water from hands.



# HDR110#SS

## Sensor Activated Clean Dry™ High Speed Concealed Hand Dryer

### SPECIFICATIONS

- Warranty: One Year Warranty
- Material: Stainless Steel
- Power Connection: Hardwired
- Power Rating: 120V AC, 4.25 Amps, 60 Hz, 510 W
- Power Saving Function: Automatically turns OFF when hands are removed or after 60 seconds of use
- Decibel Rating: 58dB
- Air Speed: 224 mph (100 meters/second); 19,950 LFM (linear feet per minute)
- Dry Time: 12 seconds\*
- Drain Tray Capacity: 0.27 gal (950 ml)
- Size: 12-5/8" x 28-3/4" x 6-7/16"
- Weight: 22 lbs (10 kg)
- Operating Temperature: 32°-104°F (0°-40°C)

\*Per tests performed at TOTO Lab.  
These dimensions and specifications are subject to change without notice.

### INSTALLATION NOTES

For handicapped installation, refer to codes. Maximum height of a blower outlet from finished floor is 47-1/4" (1200mm) to comply with ADA Guidelines ANSI A117.1 and CSA B651 requirements.

### WIRING DIAGRAM

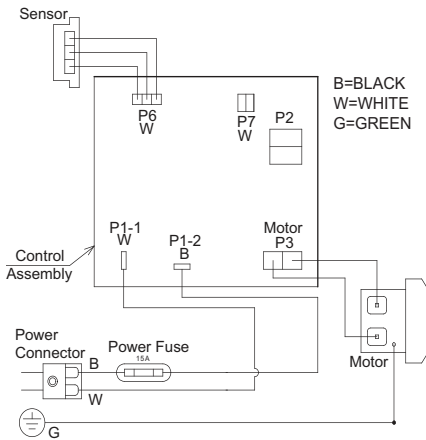

### ROUGH-IN

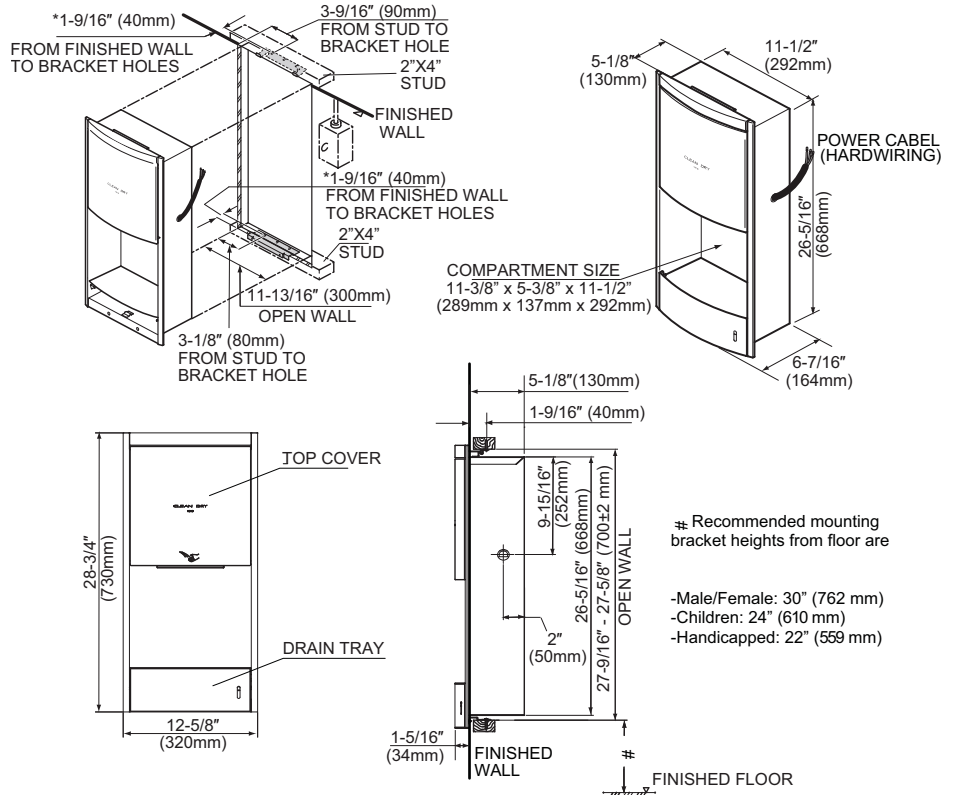

\*WALL THICKNESS REQUIREMENT: MIN 3/16 in (5mm) TO MAX. 1-3/16 (30mm)

**TOTO®**

These dimensions and specifications are subject to change without notice